

C645A-E Pressure Switches

PRODUCT DATA



FEATURES

- C645A,B models are for use on natural gas, LP gas, or air.
- C645B1047 includes a scaleplate stop to meet American Gas Association (AGA) requirements for gas-fired boilers with inputs over 2-1/2 million Btuh.
- C645C,D models are for use on air only.
- C645E for use with distillate fuel oil.
- Spring-loaded diaphragm actuates snap-acting Micro Switch.
- Switch can be wired to turn on alarm.
- C645A,C and D models break control circuit on pressure fall.
- C645B models break control circuit on pressure rise.
- Lockout and manual reset optional in A and C models.
- Removable, zinc-plated cover protects scaleplate and adjusting screw.
- Lockout models have external manual reset lever.
- Pipe tappings allow selection of positive pressure, differential-pressure, or venting connections.
- Optional switch position indicator available.
- Models of C645A,B available with cover window for setpoint visibility.
- Buna-N fiber-reinforced material for increased control diaphragm strength.
- Two seal-off diaphragms for added reliability.

GENERAL

The C645 pressure switches are safety devices used in positive-pressure or differential-pressure systems to sense gas or air pressure changes.

Contents

General	1
Features	1
Specifications	2
Ordering Information	2
Installation	4
Settings and Adjustments	6
Operation and Checkout	7



SPECIFICATIONS

Models:

C645A,C,D Pressure Switches—break a circuit when pressure falls to scale setting minus the differential. Refer to Table 1.

C645B Pressure Switches—break a circuit when pressure rises to scale setting. Refer to Table 1.

C645E—breaks circuit when pressure falls to scale setting minus the differential. Refer to Table 1.

Table 1. Pressure switch model selection.

Models	Scale Range (in. wc)	Scale Range (kPa)	Natural or LP Gas	Air	Switching Action	Switch Position Indicator	Differential Range (in. wc)		Differential Range (kPa)		Maximum Surge Pressure (psi)	Maximum Surge Pressure (kPa)	Cover Window
							Nom.	Max.	Nom.	Max.			
C645A	3 to 21	0.7 to 5.2	Yes	Yes	Auto Recycle or Lockout ^a	Optional	1	3	0.2	0.7	5	34.5	Optional
	5 to 35	1.2 to 8.7	Yes	Yes		^c	1	4	0.2	1.0	5	34.5	Yes
C645B	3 to 21	0.7 to 5.2	Yes	Yes	Lockout ^b	Yes	1	3	0.2	0.7	5	34.5	Optional
	5 to 35	1.2 to 8.7	Yes	Yes		Yes	1	4	0.2	1.0	5	34.5	Yes
C645C	0.6 to 5.3	0.1 to 1.3	No	Yes	Auto Recycle or Lockout ^a	Optional	0.2	0.8	0.05	0.02	1.5	10.3	No
	2 to 20 ^d	0.5 to 5	No	Yes	Auto Recycle	No	1	3	0.2	0.7	5	34.5	No
C645D	3 to 21	0.7 to 5.2	No	Yes	Auto Recycle	No	1	3	0.2	0.7	5	34.5	No
C645E	3 to 21	0.7 to 5.2	No	Yes	Auto Recycle	No	1	3	0.2	0.7	5	34.5	No

^a Locks out when pressure falls to setpoint minus differential; can be reset manually after pressure rises to setpoint.

^b Locks out when pressure rises to setpoint; can be manually reset after pressure falls to setpoint minus differential.

^c Without indicator on Auto Recycle; with indicator on Lockout model.

^d With surge orifice.

Switch Ratings (Amperes):

Model		120 Vac	240 Vac
C645A	Full Load	7.4	3.7
C645B	Locked Rotor	44.4	22.2
C645D			
C645C	Full Load	8.0	5.1
	Locked Rotor	48.0	30.6
C645E	Full Load	7.4	3.7
	Locked Rotor	44.4	22.2

All models also rated 2A at 30 Vac.

Alternate Electrical Ratings when used with Honeywell Flame Safeguard Programmings (all C645 models):

Ignition Transformer	540 VA
Pilot Valve	50
Main Valve	250 VA with 10 times inrush. 400 VA with 2-1/2 times inrush.

ORDERING INFORMATION

When purchasing replacement and modernization products from your TRADELINE® wholesaler or your distributor, refer to the TRADELINE® catalog or price sheets for complete ordering number, or specify—

1. Order number.
2. Air or gas control on C645A,B models.
3. Optional specifications.
4. Accessories, if desired.

If you have additional questions, need further information, or would like to comment on our products or services please write or phone:

1. Your local Honeywell Home and Building Control Sales Office (check white pages of your phone directory).
2. Honeywell Home and Building Control Customer Relations
Honeywell, 1885 Douglas Drive North
Minneapolis, Minnesota 55422-4386

In Canada—Honeywell Limited/Honeywell Limitée, 35 Dynamic Drive, Scarborough, Ontario M1V 4Z9. International sales and service offices in all principal cities of the world. Manufacturing in Australia, Canada, Finland, France, Germany, Japan, Mexico, Netherlands, Spain, Taiwan, United Kingdom, U.S.A.

Switching:

Spdt Micro Switch snap-acting switch (Fig. 3).

Minimum Ambient Temperature:

-20°F (- 29°C).

Maximum Ambient Temperature:

125°F (52°C).

Connections:

1/4-18 NPT female tapping for main or high pressure connection.

1/8-27 NPT female tapping for venting or low-pressure connection.

Approvals:

Underwriters Laboratories Inc. listed: C645AE File no. MP2168, Guide no. MFHX; for use in ambient temperatures normally prevailing in occupiable spaces, which usually are not higher than 77°F (25°C) but can occasionally be as high as 104°F (40°C) for brief periods.

Canadian Standards Association listed: C645A-E, File no. LR1620-369, Guide no. 140-A-2; for use subject to same ambient temperature restrictions as Underwriters Laboratories Inc.

Factory Mutual Approved.

Industrial Risk Insurers: C645A-D models with window in cover approvable for applications on burners over 5 million Btuh (5 thousand cfh) input.

Optional Specifications:

1. C645A with position indicator and manual reset.
2. C645A operation to 1.5 in. WC with position indicator and manual reset.
3. C645B with position indicator and manual reset.
4. C645C with position indicator and manual reset.
5. C645D with 2 in. (50.8 mm) differential.

Accessories:

1. C645A,B,D: Mounting Bracket: part no. 15865AC.
2. C645C: Mounting Bracket: part no. 112657A.
3. C645A: Cover with Window: part no. 137637B.
4. C645B: Cover with Window: part no. 137637C.

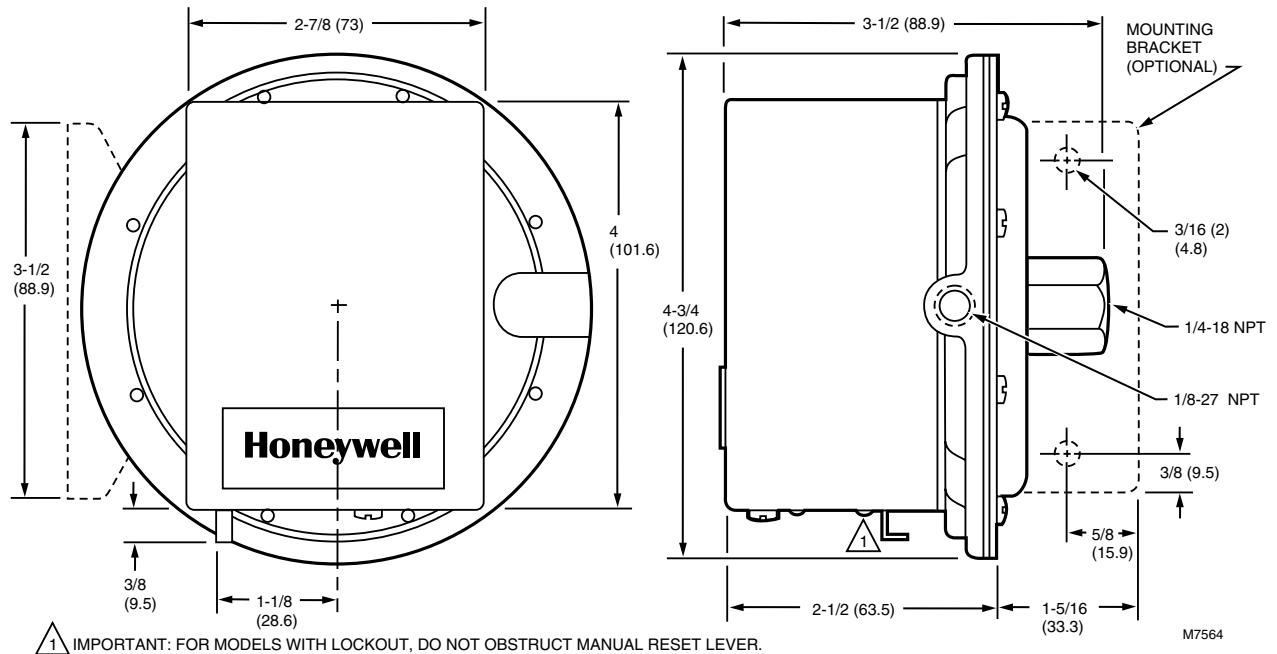

Fig. 1. Dimensions of C645A,B,D, and E in in. (mm).

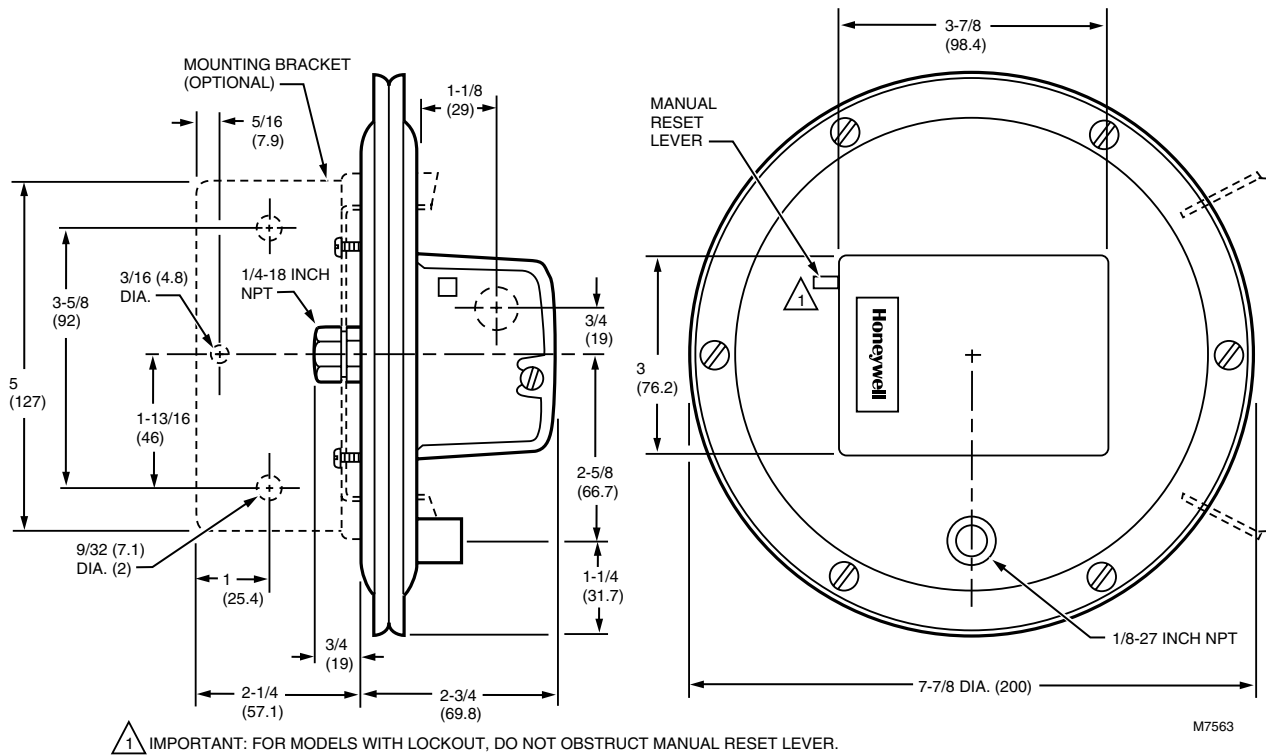

Fig. 2. Dimensions of C645C in in. (mm).

INSTALLATION

When Installing this Product . . .

- ❶ Read these instructions carefully. Failure to follow them could damage the product or cause a hazardous condition.
- ❷ Check the ratings given in the instructions and on the product to make sure the product is suitable for your application.
- ❸ Installer must be a trained, experienced service technician.
- ❹ After installation is complete, check out product operation as provided in these instructions.

CAUTION

Disconnect power supply before beginning installation to prevent electrical shock or equipment damage.

Mounting

The C645 has a hexagonal fitting with a 1/4 in. NPT tapping, which is the high pressure connection in differential applications. The bleed fitting is 1/8 in. NPT female tapped. In differential pressure control applications using air, connect the lower pressure to the bleed fitting (Fig. 3 and 4). In applications using combustible gases, vent the bleed tapping according to applicable standard code or jurisdictional authority.

The C645A,B,D can be mounted in any position but are more accurate when mounted horizontally. The C645C is mounted with the diaphragm vertical and the bleed fitting at the bottom.

The C645E1002 Distillate Fuel Oil Pressure Switch is the same as the C645A1006 Gas Pressure Switch except that it does not have a 0.015 in. (0.38 mm) diameter (nominal) orifice in its 1/4 in. NPT main (high pressure) connection. (This orifice is required in a C645A Gas Pressure Switch to restrict gas leakage, but it is too small for oil applications.) The C645E1002 has a 0.125 in. (3.18 mm) diameter (nominal) opening in its 1/4 in. NPT main connection into its pressure chamber.

! CAUTION

Vent the bleed tapping back to the oil supply tank—not to the combustion chamber.

Wiring

Disconnect power supply before connecting wiring to prevent electrical shock and equipment damage.

All wiring must agree with applicable codes, ordinances, and regulations. An opening is provided to accommodate rigid conduit or armored cable for line voltage operation (Fig. 3 and 4). Do not overload the switch contacts (see Switch Ratings in Specifications section). The switching schematic is shown in Fig. 5.

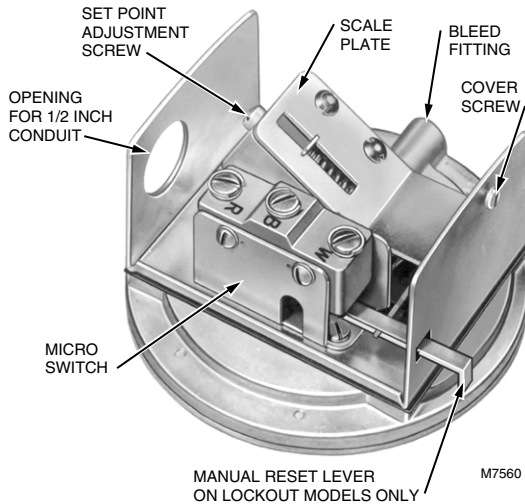

Fig. 3. C645A,B,D with cover removed.

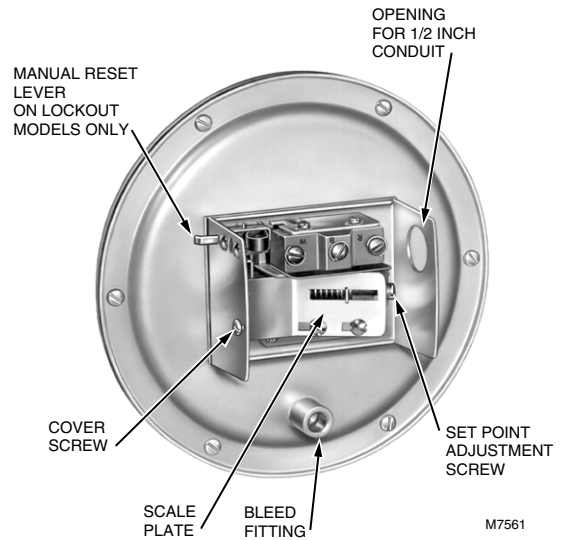
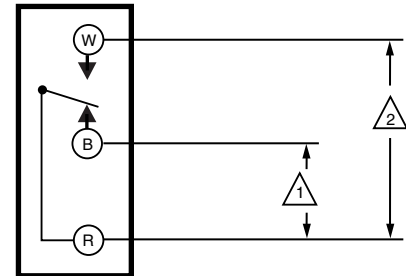

Fig. 4. C645C with cover removed.



1 C645A,C,D BREAKS R-W, MAKE R-B ON PRESSURE FALL. MANUAL RESET MODELS LOCK OUT.

2 C645B BREAKS R-B, MAKES R-W ON PRESSURE RISE AND LOCKS OUT.

M7565

Fig. 5. Schematic showing switch in zero pressure condition.

SETTINGS AND ADJUSTMENTS

Pressure Setpoint Adjustment



Tables 2 through 4 give the pressure and switching for each setpoint. To adjust the pressure setting, turn the setpoint adjustment screw (Fig. 3 and 4) clockwise  to increase the pressure setting and counterclockwise  to decrease the pressure setting.

Table 2. C645A,D,E control points.

Setpoint	Switching	Pressure in. of Water	Pressure kPa
3 ^a	R-W makes	3	0.8
	R-B makes	2	0.5
9 ^b	R-W makes	9	2.2
15 ^b	R-W makes	15	3.7
21 ^c	R-W makes	21	5.2
	R-B makes	18	4.5
35 ^d	R-W makes	35	8.7
	R-B makes	31	7.7

^a Nominal differential—1 in. of water (0.2 kPa).

^b Differential between 1 and 3 in. of water (0.2 and 0.7 kPa).

^c Maximum differential—3 in. of water (0.7 kPa).

^d Maximum differential—4 in. of water (1.0 kPa).

Table 3. C645B control points.

Setpoint	Switching	Pressure in. of Water	Pressure kPa
3 ^a	R-W makes	3	0.8
	R-B makes	2	0.5
9 ^b	R-W makes	9	2.2
15 ^b	R-W makes	15	3.7
21 ^c	R-W makes	21	5.2
	R-B makes	18	4.5
35 ^d	R-W makes	35	8.7
	R-B makes	31	7.7
45 ^e	R-W makes	45	11.2
	R-B makes	39	9.8

^a Nominal differential—1 in. of water (0.2 kPa).

^b Differential between 1 and 3 in. of water (0.2 and 0.7 kPa).

^c Maximum differential—3 in. of water (0.7 kPa).

^d Maximum differential—4 in. of water (1.0 kPa).

^e Maximum differential—5.7 in of water (1.4 kPa).

Table 4. C645C Control Points.

Setpoint	Switching	Pressure in. of Water	Pressure kPa
1 ^a	R-W makes	1	0.25
	R-B makes	0.8	0.2
3 ^b	R-W makes	3	0.75
	R-B makes	2.6	0.64
5 ^b	R-W makes	5	1.24
	R-B makes	4.3	1.2
Top Scale ^c	R-W makes	6	1.50
	R-B makes	5.2	1.3

^a Nominal differential—0.2 in. of water (0.05 kPa).

^b Differential between 0.2 and 0.8 in. of water (0.05 and 1.2 kPa).

^c Maximum differential—0.8 in. of water (0.2 kPa).

C645B1047 Scaleplate Stop Adjustment

The C645B1047 is the same as the C645B1013 except for a scaleplate stop.

Specifications

Scaleplate Stop:

Limits maximum setting, factory-set at 5-1/4 in. of water (1.31 kPa).



Scale Range:

3 to 21 in. of water (0.75 to 5.23 kPa).

Adjusting Wrench:

Part no. 23466 included with the C645B1047.

To Adjust Scaleplate Stop

- 1 Remove cover.
- 2 Loosen scaleplate stop locking screw about 1/2 turn counterclockwise  with the 23466 Adjusting Wrench.
- 3 Move scaleplate stop until *bottom* edge is aligned with desired maximum setting.
- 4 Tighten scaleplate stop locking screw clockwise .
- 5 Replace cover.

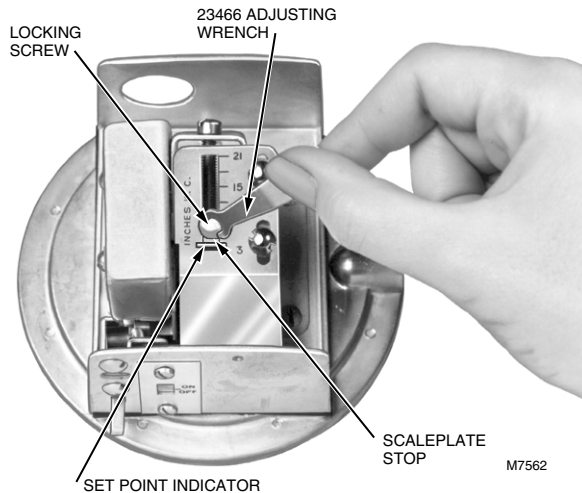

Fig. 6. Adjusting C645B1047 scaleplate stop.

Manual Resetting

The C645A,C manual reset models lock out at scale setting minus the differential and require manual resetting after the pressure rises to scale setting to resume normal operation.

The C645B locks out at scale setting and requires manual resetting after the pressure falls to scale setting minus the differential to resume normal operation. To reset, push the reset button as far as it will go; then release.

IMPORTANT

Lockout models cannot be made to recycle automatically by permanently holding in the reset lever.

OPERATION AND CHECKOUT

Operation

The C645A,C,D,E spring-loaded diaphragm actuates the Micro Switch snap-acting switch to break a control circuit when pressure falls to scale setting minus differential. The switch can be wired to turn on an alarm at the same time. When the pressure rises to the scale setting, the control circuit requires manual resetting to reset and turn off alarm. Optional C645A model will recycle automatically when the control circuit returns to scale setting.

The C645B spring-loaded diaphragm actuates the Micro Switch snap-acting switch which breaks a control circuit, locks out, and turns on an alarm (if so wired) when the pressure rises to the scale setting. When pressure falls to the scale setting minus the differential, the switch lockout can be manually reset, turning off the alarm

Checkout

C645A,B—Gas or Air Switch

- 1 Set cutoff pressure.
- 2 Open main supply line. Depress reset lever on lockout models until switch makes R-W.
- 3 Set controller and limit switch to call for heat.
- 4 For C645A—close main shutoff valve. Valve should close when pressure reaches cutoff point.
For C645B—wait a few minutes for the pressure to rise; then lower the scale setting until the switch makes R-W and locks out.

NOTE: To more accurately check C645A, use slow bleedoff. For C645B, jumper other limit and let pressure rise to cutoff setting.

- 5 For C645A—reconnect the control valve, open the shutoff valve, press the reset lever (if necessary), and return the pressure switch to its original setting.
For C645B—raise setting to normal. Depress reset lever.
- 6 Allow system to operate through at least one complete cycle to make certain all components are functioning properly.

C645C,D—Air Switch Only

- 1 Set cutoff pressure.
- 2 Turn on fan.
- 3 If using a manual reset C645, depress and hold lever until switch makes R-W.
- 4 Block fan inlet or filter area. Switch should break R-W, make R-B when pressure drops to cutoff point. Manual reset models lock out.
- 5 Remove obstruction. Depress reset lever and allow system to operate through at least one complete cycle to make certain all components are functioning properly.

C645E1002—Distillate Fuel Oil Switch

- 1 The C645E1002 is the same as the C645A1006 Gas Pressure Switch except the C645E1002 has a 0.125 in. NPT main connection in its pressure chamber.
- 2 See Checkout for C645A.

Honeywell

Home and Building Control
Honeywell Inc.
1985 Douglas Drive North
Golden Valley, Minnesota 55422

Home and Building Control
Honeywell Limited-Honeywell Limitée
35 Dynamic Drive
Scarborough, Ontario
M1V 4Z9



Printed in U.S.A. on recycled
paper containing at least 10%
post-consumer paper fibers.